

Features

Accurate and reliable heat detection for protection of property**

UL listed to Standard 521 as a rate compensated heat detector

Fixed temperature operation is suitable for most applications:

- Thermistor based design is inherently rate compensated due to minimal thermal lag
- Available for 135° F (57° C) or 200° F (93° C)
- UL and ULC spacing distance is 70 ft (21.3 m)

Available with rate-of-rise temperature detection:

- Dual thermistor rate-of-rise operation
- For use where anticipated ambient temperature changes are less than 6° F/minute (3.33° C/minute)
- UL and ULC spacing distance is 70 ft (21.3 m)

Epoxy encapsulated electronic design provides:

- Easily tested, self-restoring operation with repeatable accuracy
- Alarm indicating LED located on detector
- Current limited alarm that is compatible with two-wire initiating device circuits (IDCs)
- Designed for EMI compatibility

Optional remote alarm indicating LED

Available base options:

- Bases for 2-wire or 4-wire operation
- Auxiliary relay output (refer to selection chart on page 2 for relay ratings)
- Remote alarm indicating LED output

Description

Accurate Electronic Design. Simplex® electronic heat detectors use a fast response, thermistor based design to provide temperature sensing that quickly, accurately, and consistently identifies when fixed temperatures are exceeded. The fixed temperature sensing thermistor readily tracks the local ambient temperature. This eliminates the time required to melt a lead pellet or heat a bimetallic element as occurs in mechanical heat detector designs and provides the required heat detection for most applications.

* This product has been approved by the California State Fire Marshal (CSFM) pursuant to Section 13144.1 of the California Health and Safety Code. See CSFM Listing 7270-0026:221 for allowable values and/or conditions concerning material presented in this document. It is subject to re-examination, revision, and possible cancellation. Accepted for use – City of New York Department of Buildings – MEA35-93E. Additional listings may be applicable, contact your local Simplex product supplier for the latest status. Listings and approvals under Simplex Time Recorder Co. are the property of Tyco Safety Products Westminster.

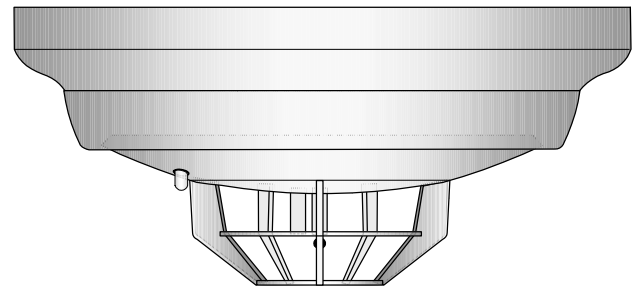

Electronic Heat Detector Mounted in Base

Description (Continued)

Rate-of-rise detection is determined by comparing two thermistor responses. By combining accurate thermistors with proper physical placement, this patented[†] rate-of-rise detection design achieves a high level of performance not normally available with mechanical detection.

Specifications

| | |
|--|---|
| Voltage | 15 to 32 VDC (filtered DC with 30% maximum ripple) |
| Standby Current | 80 µA typical, 100 µA maximum |
| Alarm Current, 2-Wire Operation | Up to 86 mA maximum, exact current is determined by alarm current limiting of connected IDC |
| Alarm Current, 4-Wire Operation | 24 mA typical @ 24 VDC |
| Rate-of-Rise Operation | Meets FM requirements for operation between 15° and 25° F/min (8.33° and 13.88° C/min) |
| Humidity Range | 10% to 95% RH from 32° to 122° F (0° to 50° C), not intended for outdoor applications |
| Color | Frost-White |
| Dimensions | Refer to diagram on page 3 |
| Ambient Temperature Operating Range | |
| 135° F Models | 32° to 100° F (0° to 38° C) |
| 200° F Models | 32° to 150° F (0° to 66° C) |

**** WARNING: In most fires, hazardous levels of smoke and toxic gas can build up before a heat detection device would initiate an alarm. In cases where Life Safety is a factor, the use of smoke detection is highly recommended.**

† Simplex electronic heat detector design is protected by U.S. Patent Numbers 5,450,066 and D377,460.

Applications Reference

Heat detectors are used where property protection is desired and where life safety protection is not required or is performed by other equipment. Typical heat detector applications are satisfied by use of these fixed temperature electronic detectors.

The addition of rate-of-rise operation provides two forms of heat detection for use where temperature fluctuations are controlled and are less than 6° F/min (3.33° C/min). Where temperatures may fluctuate more quickly, use fixed temperature detection.

Refer to NFPA 72®, the *National Fire Alarm Code*® and publication 574-709, *4098 Detectors, Sensors, and Bases Application Manual*, for additional guidance in applying and locating heat detectors.

Alarm Indicating LED Operation

The heat detector LED turns ON continuously when in alarm. During normal conditions the LED is OFF.

Fixed Temperature Guidelines

135° F (57° C) fixed temperature detectors are for normal temperatures that do not exceed 100° F (38° C).

200° F (93° C) fixed temperature detectors are for normal temperatures that exceed 100° F (38° C) but are less than 150° F (66° C).

Alarm Verification Application Note

When connecting these electronic heat detectors to a 2-wire initiating device circuit (IDC) that is providing Alarm Verification for smoke detectors, use the 4098-9682, 4-wire base. The 4-wire base provides an alarm contact that is not current-limited. (Heat detectors in the 2-wire base present a current-limited alarm condition that is not compatible with Alarm Verification. Initiating devices other than smoke detectors are required to activate the alarm without starting the alarm verification cycle.)

Heat Detector Selection Chart (compatible with bases listed below)

| Model | Fixed Temperature Operation at | Rate-of-Rise Operation | FM Ratings | | UL & ULC Maximum Spacing |
|-----------|--------------------------------|---|------------------------------------|---------------------------|------------------------------------|
| | | | Maximum Spacing | RTI (Response Time Index) | |
| 4098-9612 | 135° F (57° C) | Not applicable | 20 ft x 20 ft (6.1 m x 6.1 m) | Quick | 70 ft x 70 ft (21.3 m x 21.3 m) |
| 4098-9614 | 200° F (93° C) | | | | |
| 4098-9613 | 135° F (57° C) | Between 15° & 25° F/min (8.33° & 13.88° C/min) | 20 ft x 20 ft (6.1 m x 6.1 m) | Quick | |
| 4098-9615 | 200° F (93° C) | | 50 ft x 50 ft (15.2 m x 15.2 m) | Ultra Fast | |

Heat Detector Base Selection Chart

| Model | Description | Connection | Details |
|--------------------|---|-----------------------------|--|
| 4098-9788 | 2-Wire Base , no options | IDC connections | Screw terminals for in/out wiring, 18 to 14 AWG |
| 4098-9684 | 2-Wire Base with connection for remote LED alarm indicator | IDC connections | Screw terminals for 18 to 14 AWG for in/out wiring of zone (+), color coded 18 AWG leads for in/out wiring of zone (-) |
| | | LED connections | Color coded 18 AWG leads |
| 4098-9683 | 2-Wire Base with auxiliary alarm relay output NOTE: Must be connected as the only device on the IDC to ensure relay operation. | Relay Operation Type | Relay Ratings |
| | | Power-limited | 1 A @ 28 VDC |
| | | Nonpower-limited | 3 A @ 120 AC |
| | | Output Type | Wiring Connections |
| 4098-9682 | 4-Wire Base with auxiliary alarm relay output NOTE: Requires separate 24 VDC power. | IDC connections | Screw terminals for 18 to 14 AWG for in/out wiring of zone (+), color coded 18 AWG leads for in/out wiring of zone (-) |
| | | Relay connections | Color coded 18 AWG leads |
| | | Relay Operation Type | Relay Ratings |
| | | Power-limited | 3 A @ 28 VDC |
| | | Nonpower limited | 3 A @ 120 AC |
| Output Type | Wiring Connections | | |
| 4098-9682 | 4-Wire Base with auxiliary alarm relay output NOTE: Requires separate 24 VDC power. | IDC connections | Color coded 18 AWG leads for in/out wiring |
| | | Relay connections | Color coded 18 AWG leads |
| | | Power connections | Screw terminals for 18 to 14 AWG for in/out wiring of power (+), color coded 18 AWG leads for in/out wiring of power (-) |

Metric wire equivalents: 18 AWG = 0.82 mm²; 14 AWG = 2.08 mm²

Heat Detector Accessories

| Model | Description | Details | Base Compatibility |
|-----------|--------------------------------|---|---|
| 4098-9832 | Adapter Plate | Required for surface or semi-flush mounting to 4" (102 mm) square electrical box or for surface mounting to 4" octagonal box | 4098-9682 4098-9683 4098-9684 4098-9788 |
| | | May also be used when retrofitting to replace existing larger diameter bases | |
| 4098-9830 | Remote Red LED Alarm Indicator | Mounted on single gang stainless steel plate, wiring connections are 18 AWG color coded leads | 4098-9684 only |
| 2098-9739 | End-of-Line Relay | Epoxy encapsulated design, 24 VDC operation, wiring connections are 18 AWG color coded leads | For 4-wire IDCs using 4098-9682 base, one per circuit |
| 2098-9735 | End-of-Line Relay | Mounted on single gang stainless steel plate, 24 VDC operation, wiring connections are 18 AWG color coded leads | |

Metric wire equivalent: 18 AWG = 0.82 mm²

Dimensions and Reference

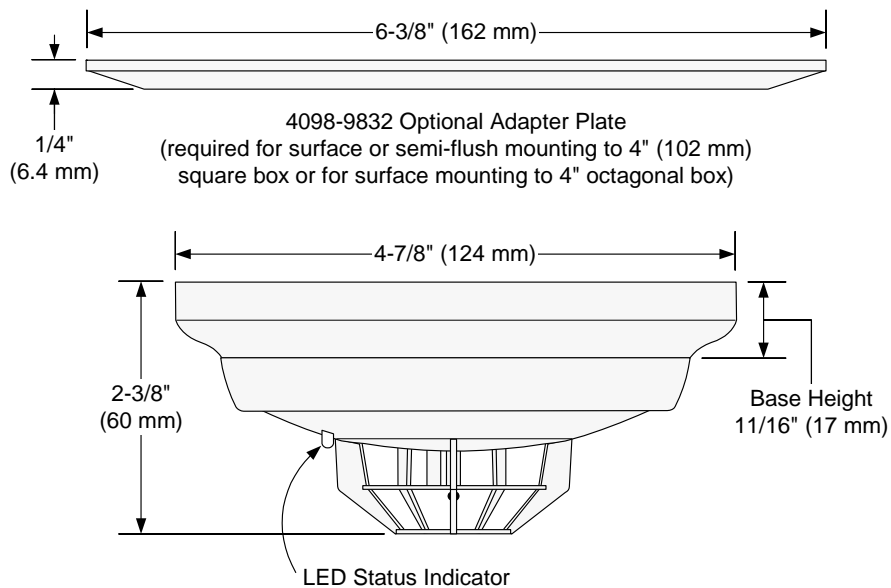

4098-9830 Remote Red LED Alarm Indicator (not to scale)

Mounting Information

| Base | Electrical Box Requirements |
|-------------------------------------|--|
| 4098-9788 | 4" (102 mm) octagonal or 4" square box, 1-1/2" deep (38 mm) |
| | Single gang box, 2" deep (51 mm) |
| 4098-9682 4098-9683 4098-9684 | 4" octagonal or 4" square box, 1-1/2" deep with 1-1/2" deep extension ring (see diagram below) |

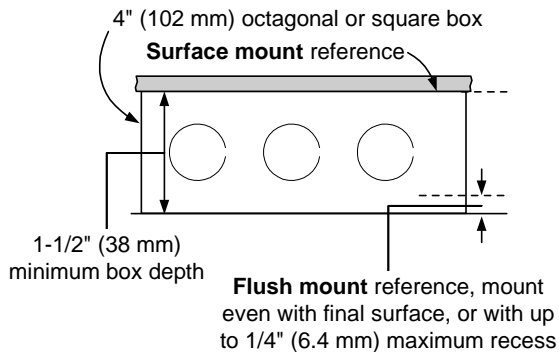

4098-9832 Adapter Plate, required for surface or semi-flush mounting to 4" square box or for surface mounting to 4" octagonal box

Bases 4098-9682 and 4098-9683 include a relay that mounts in base electrical box

Base 4098-9684 includes a remote LED interface module that mounts in base electrical box

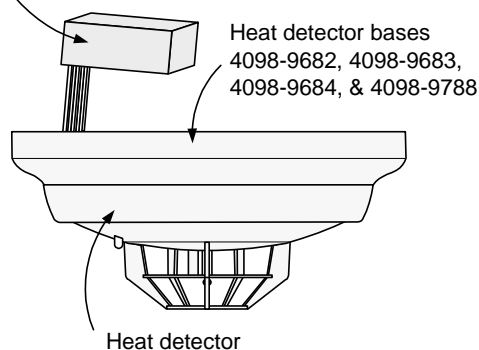

NOTE: Refer to Installation Instructions 574-706 for additional information.

Applications Reference

The following table provides a reference for the maximum rectangular area covered for detectors rated with the given spacing. For additional information, including consideration of ceiling height, refer to NFPA 72, the *National Fire Alarm Code*.

Maximum Rectangular Area Dimensions for Single Detector Coverage

| 20 ft Rated Spacing (6.1 m) | 50 ft Rated Spacing (15.2 m) | 70 ft Rated Spacing (21.3 m) |
|------------------------------------|--------------------------------------|--------------------------------------|
| 20 ft x 20 ft (6.1 m x 6.1 m) | 50 ft x 50 ft (15.2 m x 15.2 m) | 70 ft x 70 ft (21.3 m x 21.3 m) |
| 15 ft x 23.9 ft (4.5 m x 7.2 m) | 45 ft x 54.5 ft (13.7 m x 16.6 m) | 65 ft x 74.6 ft (19.8 m x 22.7 m) |
| 10 ft x 26.4 ft (3 m x 8 m) | 40 ft x 58.2 ft (12.1 m x 17.7 m) | 60 ft x 78.7 ft (18.3 m x 24 m) |
| 5 ft x 27.8 ft (1.5 m x 8.4 m) | 35 ft x 61.4 ft (10.6 m x 18.7 m) | 55 ft x 82.3 ft (16.7 m x 25 m) |
| 1 ft x 28.2 ft (0.3 m x 8.5 m) | 30 ft x 64 ft (9.1 m x 19.5 m) | 50 ft x 85.4 ft (15.2 m x 26 m) |
| | 25 ft x 66.1 ft (7.6 m x 20.1 m) | 45 ft x 88.1 ft (13.7 m x 26.8 m) |
| | 20 ft x 67.8 ft (6.1 m x 20.6 m) | 40 ft x 90.5 ft (12.2 m x 27.5 m) |
| | 15 ft x 69 ft (4.5 m x 21 m) | 35 ft x 92.6 ft (10.6 m x 28.2 m) |
| | 10 ft x 69.9 ft (3.5 m x 21.3 m) | 30 ft x 94.3 ft (9.1 m x 28.7 m) |
| | 5 ft x 70.5 ft (1.5 m x 21.4 m) | 25 ft x 95.7 ft (7.6 m x 29.1 m) |
| | 1 ft x 70.6 ft (0.3 m x 21.5 m) | 20 ft x 96.9 ft (6.1 m x 29.5 m) |
| | | 15 ft x 97.8 ft (4.5 m x 29.8 m) |
| | | 10 ft x 98.4 ft (3.05 m x 30 m) |
| | | 5 ft x 98.8 ft (1.5 m x 30.1 m) |
| | | 1 ft x 99 ft (0.3 m x 30.2 m) |

Tyco is a registered trademark of Tyco International Services GMBH and is used under license. Simplex, and the Simplex logo are trademarks of Tyco International Ltd. and its affiliates and are used under license. NFPA 72 and National Fire Alarm Code are trademarks of the National Fire Protection Association (NFPA).