

BOSCH

Invented for life

FPA-5000 With Functional Modules



- ▶ **Modular configuration allowing for easy extension**
- ▶ **Easy adaptation to country-specific regulations and conditions**
- ▶ **Complete set-up with up to 46 modules per control panel**
- ▶ **Interconnection of up to 32 Panel Controllers, Remote Keypads, and OPC server**
- ▶ **Loop or bus connection with redundancy**
- ▶ **Connection to BIS Building Integration System via OPC server**
- ▶ **Control of up to 4096 addresses (stand-alone panel), or of up to 32512 addresses of a network with 2032 addresses per control panel**
- ▶ **Installation and auto-detection of functional modules by simply inserting them into the Panel Rail**
- ▶ **Large LCD display with touch screen**

Thanks to the modular configuration, the innovative FPA-5000 Modular Fire Panel is easily adapted to local circumstances and regulations. Due to the different functional modules, country-specific characteristics are accommodated in the connection just as quickly as the respective alarm handling.

The fire panel is available with two different housings:

- Housing for mounting directly on the wall
- Frame installation housings which are fitted to the mounting frame and can be swiveled.

With the aid of special mounting kits, the housings can be mounted in 482.6 mm (19") cabinets.

All housings can be extended with various additional housings for all conceivable applications.

The entire fire detection system is configured via a laptop using the new programming software FSP-5000-RPS.

Thanks to the external CAN bus interface, several Panel Controllers and Remote Keypads can be interconnected. Using either a loop structure or bus structure, the network adapts to every application conditions.

FPA-5000 systems can be connected to the Bosch UGM 2020 Universal Security System and thus, be integrated into a large network system.

An Ethernet interface allows for the connection to a Building Management System (BIS Bosch Building Integration System) via an OPC server.

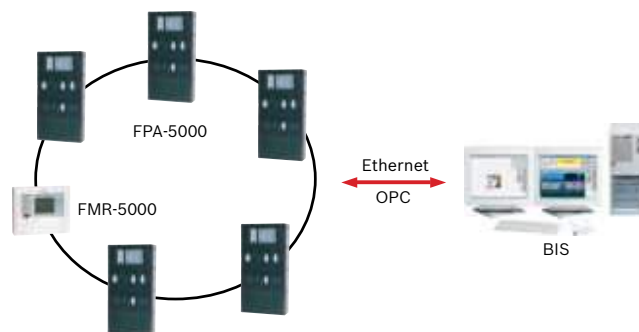

The FMR-5000 Remote Keypad offers the decentralized operation of a control panel or control panel network.

System Overview

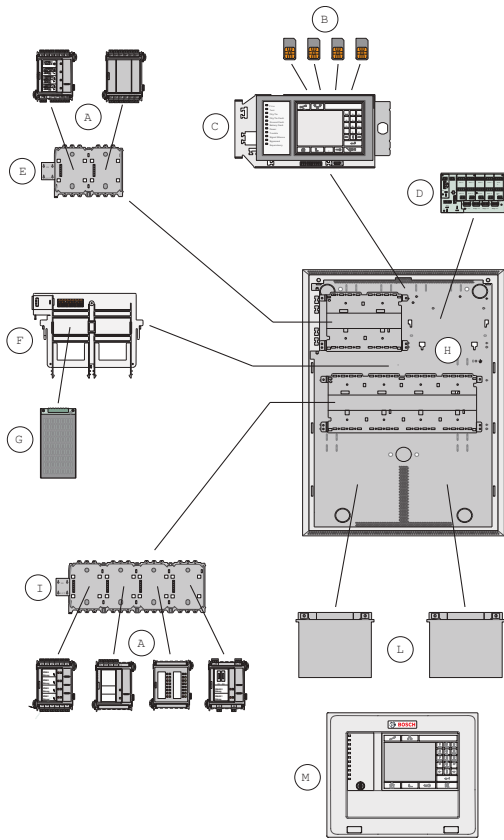

Pos.	Description
A	Functional Modules
B	ADC Address Cards
C	Panel Controller
D	Distributor, optional (RLE/RLU/HPD)
E	Panel Rail Short
F	Power Supply Bracket (installed in Frame Installation Housings ex-works)
G	Power Supply
H	Housing (in this case: HCP 0006 A)
I	Panel Rail Long
L	Batteries
M	Remote Keypad

Functions

Modular Structure of the FPA-5000 Modular Fire Panel

Due to its modular structure, the FPA-5000 Modular Fire Panel provides complete flexibility and thus customized solutions for any application.

Depending on the requirements, the following selection can be made when planning:

1. Housing type: Frame installation or wall-mount

- Selection of a basic housing
 - Optional Extension Housings
 - Optional Power Supply Housings
 - Optional kits for installation in 482.6 mm (19") racks
2. Operating and Display Unit with Panel Controller
 - Selection from the various language variants
 3. Panel Rail
 - Selection according to housing type and/or number of required functional modules
 4. Functional modules
 - Selection based on planning and country-specific requirements
 5. Power supply
 - Batteries
 - Additional power supply facilities
 - Power Supply Brackets are preinstalled ex-works for Frame Installation Housings
 - For Wall-mount Housings, Power Supply Brackets are selected as needed
 6. Additional accessories
 - Front Doors
 - Printer with Frame Installation Housing
 - Cable Sets for special applications

Modules

The functional modules are autonomous, encapsulated units that can be inserted into any control panel slot using "plug-and-play" technology. Thus, the power supply and the data traffic to the control panel are indicated automatically without any additional settings. The module is automatically identified by the control panel and functions in the default operating mode.

Wiring to external components is performed using compact connector/screw terminals.

After a replacement, only the connectors need to be reinserted; extensive rewiring is no longer required.

Module	Description
BCM-0000-B	Battery Controller Module <ul style="list-style-type: none"> • module that controls batteries and power supply
ANI 0016 A	Annunciator Module <ul style="list-style-type: none"> • with 16 red and 16 yellow LEDs, freely programmable
LSN 0300 A	LSN improved Module 300 mA <ul style="list-style-type: none"> • for the connection of an LSN loop with up to 254 LSN improved elements or 127 standard LSN elements, maximum line current 300 mA
LSN 1500 A	LSN improved Modul 1500 mA <ul style="list-style-type: none"> • for the connection of an LSN loop with up to 254 LSN improved elements, maximum line current 1500 mA, or with up to 127 standard LSN elements, maximum line current 300 mA
FPE-5000-UGM	Interface Module <ul style="list-style-type: none"> • for the connection to a UGM-2020 System
CZM 0004 A	4 Zone Conventional Module <ul style="list-style-type: none"> • for the connection of existing conventional peripherals, with four monitored conventional lines

Module	Description
IOS 0020 A	20 mA Communication Module <ul style="list-style-type: none"> sports an S20 interface, an RS232 interface and an S1 interface for a connection with a voice alarm system Ple-na via RS232
IOS 0232 A	RS232 Communication Module <ul style="list-style-type: none"> with two RS323 interfaces for a connection with a voice alarm system Ple-na, a printer or laptop
ENO 0000 B	Fire Service Interface Module <ul style="list-style-type: none"> for the connection to fire service equipment according to DIN 14675
IOP 0008 A	Input/Output Module <ul style="list-style-type: none"> with 8 digital inputs and 8 open collector outputs
RML 0008 A	Relay Module <ul style="list-style-type: none"> with 8 relays for low voltage applications
RMH 0002 A	Relay Module <ul style="list-style-type: none"> with 2 relays for mains power (250 V) and with feedback inputs (can also be used as an interface to extinguishing systems)
NZM 0002 A	Notification Appliance Zone Module <ul style="list-style-type: none"> with two monitored primary lines

Networking

Up to 32 Panel Controllers, Remote Keypads, and OPC server can be connected to a single FPA-5000 network. Depending on the usage, Panel Controllers and Remote Keypads can either be defined as a group or as a network or as a local node. Within a group, only the conditions of the control panels belonging to the defined group can be displayed. From the network nodes, the conditions of all control panels, regardless of their classification as a group, can be displayed and edited.

When networking via CAN1 and CAN2 interfaces, there are the following three connection topologies:

- Non-redundant bus via CAN1
- Redundant bus via busses CAN1 and CAN2
- Redundant loop via CAN1 and CAN2

For networking with optical fibers, you can use various converters. For detailed information on suitable converter types and maximum line lengths, refer to the FPA-5000 System Description (available online for download).

Detection Points

The Address Cards activate detection points. The FPA-5000 governs up to 4096 detection points.

Each element and input which, after the programming, is able to set off an alarm requires a detection point.

Inputs are considered as detection points if they are programmed accordingly in the FSP-5000-RPS Programming Software.

This applies to all manual call points and automatic detectors as well as to the following modules and interfaces because of their inputs:

Modules	Detection Points
CZM 0004 A	up to 4
IOP 0008 A	up to 8
ENO 0000 B	requires a detection point only if an FSE release element is connected and programmed via the FSP-5000-RPS programming software
Interfaces	Detection Points
FLM-420/4-CON	up to 2
FLM-420-I8R1-S	up to 8
FLM-420-I2	up to 2
FLM-420-O8I2-S	up to 2
FLM-420-O1I1	up to 1
FLM-420-RLE-S	up to 2
FLM-420-EOL-2W-W	1 detection point for each interface

The following interfaces do not require the allocation of detection points: FLM-420-NAC, FLM-420-RHV, FLM-420-RLV1, FLM-420-RLV8, FLM-420-O2.

Signaling devices and outputs have no detection points!

Certifications and Approvals

The provided options according to EN 54-2:1997/A1:2006 include:

- Output to fire alarm devices
- Control of fire alarm routing equipment
 - Output to fire alarm routing equipment
 - Alarm confirmation input from fire alarm routing equipment
- Outputs to fire protection equipment
 - Output type A
 - Output type B
 - Output type C
 - Fault monitoring of fire protection equipment
- Delays to outputs
- Dependencies on more than one alarm signal
 - Type A dependency
 - Type B dependency
- Alarm counter
- Fault warning condition
 - Fault signals from points
 - Total loss of the power supply
 - Output to fault warning routing equipment
- Disabled condition
 - Disablement of addressable points
- Test condition

Region	Certification
Germany	VdS-S S205106 BS FPA
	VdS G 205106 FPA-5000
	DIBt Z-6.5-2027 (B) FSA 5000 LSN
	Z-6.5-2027 (E) FSA 5000 LSN
Switzerland	VKF AEAI 19197 FPA-1200_FPA-5000 Brandmeldesystem

Region	Certification	
Europe	CE	FPA-5000
	CPD	0786-CPD-20818 FPA 5000
Austria	PFB	007/BM-PSys/019/1 FPA-1200/5000 Brandmeldesystem
		007/BM-PSys/020/1 FPA-1200/5000 Brandfallsteuerzentrale
		007/BM-PSys/021 FPA-5000 Hierarchie
Belgium	BOSEC	TCC2-894 FPA-1200_FPA-5000
Poland	CNBOP	2662/2008 FPA-5000
		0400/2008 FPA-5000
Czech Republic	TZÚS	080-011414 FPA-5000
Hungary	TMT	TMT-32/2005 FPA-5000
	MOE	UA1.016.0008784-11 FPA 5000
Macao	CB	4620/DT/2010 FPA-5000
Singapore	PSB	022767 FPA-5000

Installation/Configuration Notes

- Country-specific standards and guidelines must be considered during planning.
- Connection conditions for the regional authorities and institutions (police, fire service) must be maintained.
- It is preferable to use the loop formation owing to the greater security of loop lines compared with stub lines.
- It is possible to combine LSN interface modules and LSN detectors on one loop or stub line.
- For a mixed connection of LSN classic elements and LSN improved elements, a maximum of 127 elements are permitted.
- Existing conventional detectors can be connected to a CZM 0004 A module. A CZM 0004 A module provides four DC primary lines (zones).
- In accordance with EN 54-2, control panels with more than 512 detectors / call points must be connected redundantly. To that end, a second basic housing with a second MPC Panel Controller is used.
- For operation of the fire detection system according to EN 54-13, it is necessary to terminate every stub and T-tap with EOL-modules.

General System Limits

	Max. number
Control Panels/Remote Keypads/OPC server in network	
• Loop topology	32
• Bus topology	8
Addresses	
• Stand-alone	4096 stand-alone
• In Network	32512

	Max. number
• In network, per control panel	2032
Detection points / detector zones	
• Stand-alone	4096 stand-alone
• In Network	32512
• In network, per control panel	2032

Limits per Fire Panel

Sets, e.g. bypass group	128
Total number of modules, per control panel	46
Printer	4
Alarm counter (external, internal, revision)	3
Number of entries in the event database	10000
FSP-5000-RPS programming interface	1
Time control channel	20
Time control programs	19
Programming defined days	365
User	10
Access level	4

System Limits Functional Modules

Functional module	Max. number
BCM-0000-B	8
ANI 0016 A	32
LSN 0300 A	32
LSN 1500 A	11
FPE-5000-UGM	4
CZM 0004 A	32
IOS 0020 A	4
IOS 0232 A	4
ENO 0000 B	8
IOP 0008 A	32
RML 0008 A	32
RMH 0002 A	32
NZM 0002 A	8

System Limits for Each LSN 0300 A Module

- Up to 254 LSN improved version elements or 127 classic LSN elements can be connected
- Output current
 - LSN 0300 A: up to 300 mA
 - LSN 1500 A: up to 1500 mA
- Cable length
 - LSN 0300 A: up to 1600 m
 - LSN 1500 A: up to 3000 m
- Unshielded cables can be used

Note Owing to the FSD (Fire System Designer) programming software, the planning of fire panels in compliance with the limits (e.g. concerning cable length and power supply) is quick and easy.

Installation Notes

- Fire panels can only be installed in dry, clean interior rooms.
- To ensure optimum battery service life, the control panel should only be operated at sites with normal room temperatures.
- The following environmental conditions must be noted:
 - Permissible ambient temperature: -5 °C – 50 °C
 - Permissible relative humidity: Max. 95 %, non-condensing
- Operating and display elements should be located at eye level.
- Frame installation housings require at least 230 mm free space on the right next to the last housing; this space is for swiveling out the attached housing for connection, maintenance, and service.
- Sufficient space should be left underneath and next to the control panel for any possible extensions, e.g. for an additional power supply or an extension housing.
- Do not operate devices showing condensation.
- Only use the mounting materials specified by BOSCH ST. Interference resistance cannot otherwise be guaranteed.
- If connected to a Building Management System (BIS Bosch Building Integration System) via the Ethernet and an OPC server, please verify with the responsible network administrator that in case of a network spanning multiple buildings
 - the network is designed for connections across multiple buildings (e.g. no interference by different potentials of the ground connection)
 - all users are assigned to the network.

Ordering Information

BCM-0000-B Battery Controller Module monitors the power supply of the fire panel and the charging of the batteries	BCM-0000-B
ANI 0016 A Annunciator Module displays the status of 16 individually programmable detection points	ANI 0016 A
LSN 0300 A LSN improved Module 300 mA for connecting an LSN loop with up to 254 LSN improved elements or 127 classic LSN elements, with a maximum line current of 300 mA	LSN 0300 A
FLM-420-EOL2W-W EOL Module LSN for EN 54-13 compliant termination of LSN stubs or T-taps	FLM-420-EOL2W-W
LSN 1500 A LSN improved Module 1500 mA for connecting an LSN loop with up to 254 LSN improved elements with a maximum line current of 1500 mA, or with up to 127 classic LSN elements, with a maximum line current of 300 mA	LSN 1500 A

Ordering Information

FLM-420-EOL2W-W EOL Module LSN for EN 54-13 compliant termination of LSN stubs or T-taps	FLM-420-EOL2W-W
FPE-5000-UGM Interface Module for connecting the fire panels FPA-5000 and FPA-1200 to superordinate systems (UGM 2020, FAT 2002/RE, FSM-2000)	FPE-5000-UGM
CZM 0004 A 4 Zone Conventional Module for connecting conventional peripherals; provides four monitored conventional lines	CZM 0004 A
FLM-320-EOL2W Conventional EOL Module 2-Wire for EN 54-13 compliant termination of conventional lines	FLM-320-EOL2W
IOS 0020 A 20 mA Communication Module provides one interface each of S20, RS232 and S1	IOS 0020 A
IOS 0232 A RS232 Communication Module for connecting two devices, e.g. voice alarm system Plena, a laptop or a printer, via two independent serial interfaces	IOS 0232 A
ENO 0000 B Fire Service Interface Module for connecting fire service equipment in compliance with DIN 14675	ENO 0000 B
CPA 0000 A Cable Set AT 2000 Used to connect an AT 2000 to the MPC and the ENO 0000 B.	CPA 0000 A
IOP 0008 A Input/Output Module for individual displays or flexible connection of various electrical devices, providing eight independent digital inputs and eight open collector outputs	IOP 0008 A
RML 0008 A Relay Module provides 8 change-over contact relays (type C) for low voltage	RML 0008 A
RMH 0002 A Relay Module provides 2 change-over contact relays (type C) for high voltage, for monitored connection of external elements with feedback	RMH 0002 A
NZM 0002 A Notification Appliance Zone Module for connecting 2 separate notification appliance zone lines, provides 2 monitored primary lines	NZM 0002 A
NMC 0000 A Cable HPD/NZM Used for synchronization in accordance with UL requirements, cable length 90 cm	NMC 0000 A

Ordering Information

Accessories

FLM-320-EOL2W Conventional EOL Module 2-Wire for EN 54-13 compliant termination of conventional lines	FLM-320-EOL2W
FLM-420-EOL2W-W EOL Module LSN for EN 54-13 compliant termination of LSN stubs or T-taps	FLM-420-EOL2W-W
FDP 0001 A Dummy Cover Plate For available module slots	FDP 0001 A
PSK 0001 A Labelling Strips, Wide 20 sheets each with 6 strips, printable, for the functional modules BCM-0000-B, LSN 0300 A, LSN 1500 A, CZM 0004 A, NZM 0002 A, RMH 0002 A, CTM 0002 A and ENO 0000 B	PSK 0001 A
PSL 0001 A Labelling Strips, Small 20 sheets each with 10 strips, printable, for the ANI I0016 A Annunciator Module	PSL 0001 A

Americas:
 Bosch Security Systems, Inc.
 130 Perinton Parkway
 Fairport, New York, 14450, USA
 Phone: +1 800 289 0096
 Fax: +1 585 223 9180
 security.sales@us.bosch.com
 www.boschsecurity.us

Europe, Middle East, Africa:
 Bosch Security Systems B.V.
 P.O. Box 80002
 5600 JB Eindhoven, The Netherlands
 Phone: + 31 40 2577 284
 Fax: +31 40 2577 330
 emea.securitysystems@bosch.com
 www.boschsecurity.com

Asia-Pacific:
 Robert Bosch (SEA) Pte Ltd, Security Systems
 11 Bishan Street 21
 Singapore 573943
 Phone: +65 6258 5511
 Fax: +65 6571 2698
 apr.securitysystems@bosch.com
 www.boschsecurity.asia

Represented by