

FRRU004-CIZM4

CONVENTIONAL INITIATING ZONE MODULE



Features

- One simple LED for status indication
- NFPA Class A (Styles 6 & 7) and Class B (Style 4) for SLC
- NFPA Class A (Style D) and Class B (Style B) for IDC
- Electronic address setting
- Downsized unit
- Easy installation



Description

The Conventional Initiating Zone Module (FRRU004-CIZM4) is used to supervise the status of conventional initiating devices connected on an Initiating device circuit (IDC). The FRRU004-CIZM4 detects an alarm condition and reports to the Fire Alarm Control Panel (FACP). The FRRU004-CIZM4 module also supervises the initiating device wiring (A+, A-, B+, and B- wires) and wiring for the power supply connected to terminals 24+ and 24- to detect an open circuit. IDC wiring style is applicable to the NFPA Class B (Style B) & Class A (Style D). When the FRRU004-CIZM4 module detects an alarm, the module is latched until the system reset. When the FRRU004-CIZM4 module is used with Class A (Style D) wiring condition and detects an open circuit on wiring of the IDC and power supply connected to terminal 24+ and 24-, the module is also latched until the system reset.

The FRRU004-CIZM4 module has one red LED for local indication of the statuses of module itself and its wiring. Normal conditions are indicated by flashing LED. Alarm condition is indicated by constant illumination. Open circuit condition is indicated by extinction.

Ordering Information

Model no. FRRU004-CIZM4

Specifications

No.	Item	Specification
1	Rated voltage range of SLC input power (S+,S-)	22.0 to 24.0V
2	Maximum SLC 24 VDC standby current (S+,S-)	250μA
3	Maximum SLC 24 VDC alarm current (S+,S-)	1mA
4	Operating voltage of external power supply line (24+,24-)	24V
5	Output voltage range of IDC (A+,A-,B+,B-)	15.7 to 22.6V
6	Maximum module standby current of IDC 24 VDC (24+,24-)	8.5mA in Style B, 4.9mA in Style D
7	Maximum detector standby current of IDC 24 VDC (24+,24-)	2.4mA
8	Maximum module and detector alarm current of IDC 24 VDC (24+,24-)	50.0mA
9	Applicable IDC wiring style	Class A (Style D), Class B (Style B)
10	Maximum wiring resistance of IDC	100Ω
11	Maximum wiring capacitance of IDC	1μF
12	End-of-line resistor for IDC in NFPA Style B wiring	5.1kΩ, 1/2W
13	Maximum alarm reset voltage	0V
14	Minimum alarm reset time	1.1 second
15	Operating temperature range	0°C to 49°C (32°F to 120°F)
16	Operating humidity range	0 to 93% (non-condensing)
17	Dimensions	106mm (4.17 inches) (H) × 106mm (4.17 inches) (W) × 29mm (1.14 inches) (D)
18	Applicable electrical box for installation	North American 64mm (2-1/2 inches) deep 2-gang box Standard 4 inches square box 38mm (1-1/2 inch) deep box

Setting the Address

Each addressable module, smoke detector, heat detector and combination detector must have the address set before connecting the device to the Signaling Line Circuit (SLC) loop. The address is set using the hand held device programmer or the addressing feature on the control panel.

Installation

Figure 1: Installation into the compatible electrical box

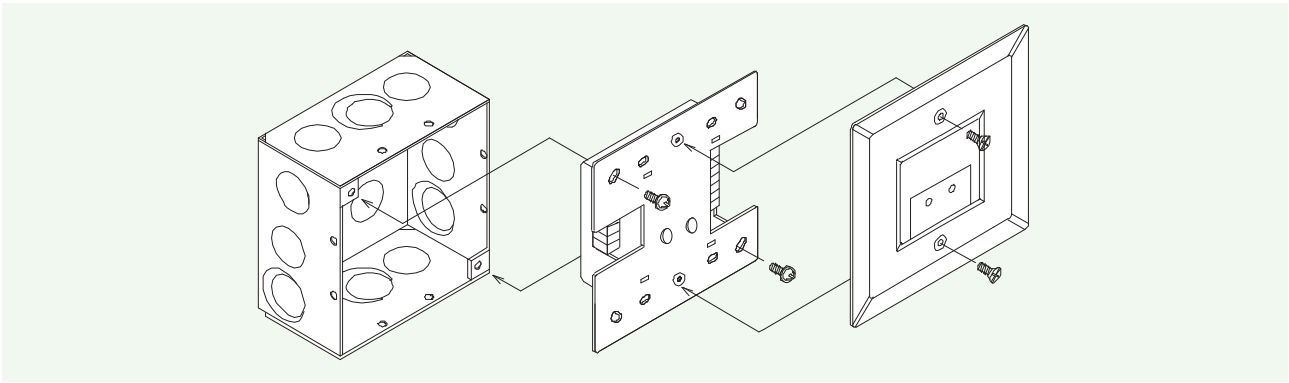

Wiring Diagram

Figure 2: Wiring diagram of FRRU004-CIZM4 in case of NFPA Class B (Style B)

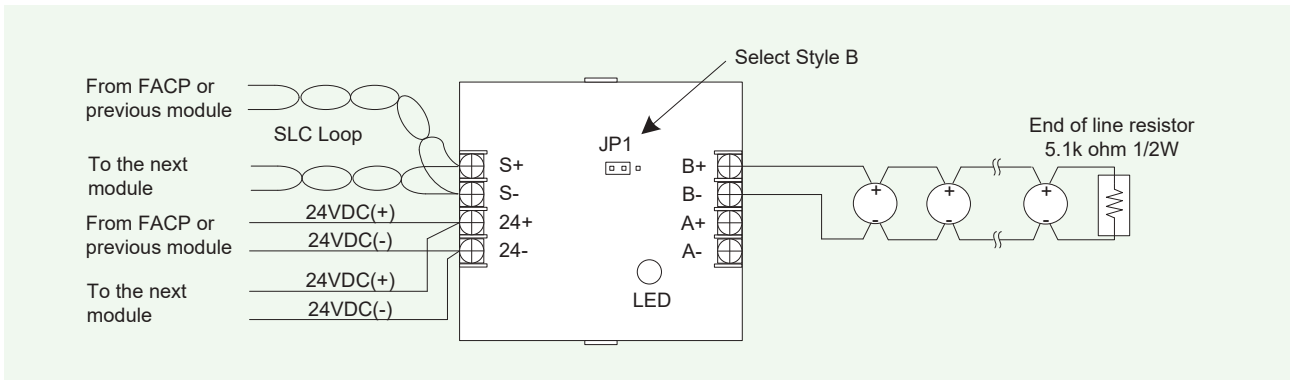
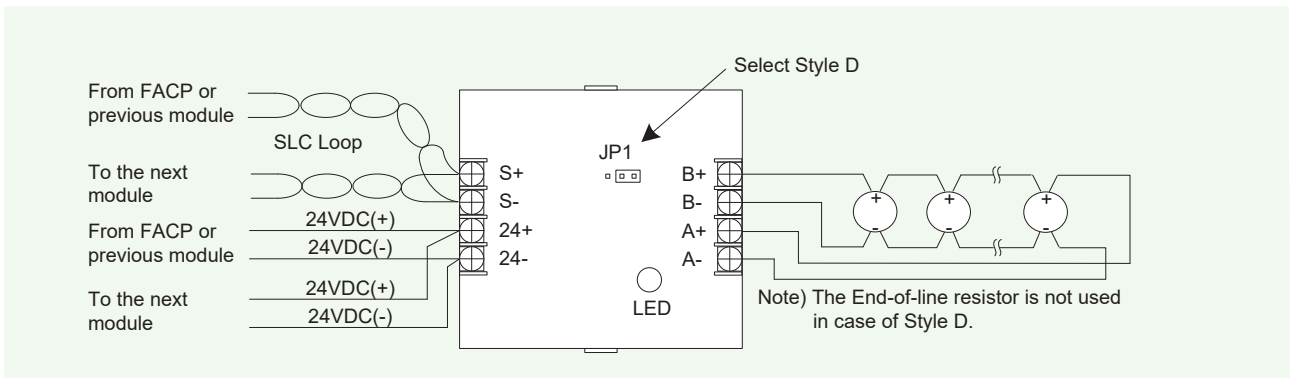

Figure 3: Wiring diagram of FRRU004-CIZM4 in case of NFPA Class A (Style D)



NOTE

- The information contained herein does not purport to cover all the details or variations of the equipment described, nor to provide for every possible contingency that may be met in connection with its installation, operation or maintenance.
- Specifications are subject to change without notice. Contact Nohmi before relying on the information.
- Actual performance is based on proper application of the product by a qualified professional.
- Should further information be required or should particular concerns arise that are not covered sufficiently for the purchaser's purposes, the matter should be referred to Nohmi or your nearest distributor.

NOHMI
NOHMI BOSAI LTD.

• Head Office: 4-7-3 Kudan-Minami, Chiyoda-ku, Tokyo
102-8277, Japan
• Phone: (81)3-3265-0231
• F A X: (81)3-3265-5348
URL <http://www.nohmi.co.jp/english/>

Contact