

MCP Indoor Call Point Range

MCP₁ Resistor & Clean Contact Model (Red Versions)



> Product Benefits

- Unique 'Plug & Play' installation concept
- Total 'Flex-Ability' in the choice of operating element
- Anti-Tamper facility
- Enhanced aesthetics
- Fully approved to the latest standards
- Backward compatibility
- CPD Approved



166b/39 &
166b/40



G206061



Product Overview

Installation efficiency, flexibility and full compliance with the latest standards are at the heart of the new MCP indoor call point range.

Installation time and ultimately cost, are of paramount importance to any fire or security installer. The MCP range directly reflects this need by providing a unique 'plug and play' concept designed specifically to reduce installation time. All new MCP products utilise a special terminal block, where all initial installation cabling is terminated. This terminal block is then simply connected to the back of the MCP. Simple, but effective, with no re-termination required and no time wasted.

Through new standards and legislation, both break glass and resettable operating elements can now be used within a manual call point. To provide you with the greatest 'flex-ability', the new MCP range can be configured as either a break glass or resettable unit by simply changing from one element to another. No other additional parts or alternative products need to be ordered.

All MCP indoor call point products also help preserve the integrity of the overall system as illegal removal of the product lid will result in the call point operating and the system going into alarm.

Full compliance with the latest standards is essential and the new MCP indoor call point range is fully approved to the latest EN54-11 standard (*Compliant markings only*).

The MCP1A product version is supplied with both a resistor and normally open clean contact electrical options. These options are easily utilised by simply connecting the terminal block to the required connection in the back of the MCP1 product. A variety of resistor versions are available, with both 470Ω and 680Ω offered as standard. However, other resistor types can be provided upon request. The MCP1B product version allows for connection to 'Sawwire' systems.

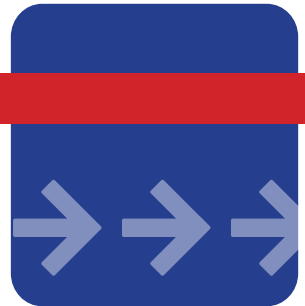

Electrical Specification

Connection Details: See Figure .1
 Cable Termination: 0.5-2.5mm²
 Maximum Voltage: 30VDC
 Current Rating (switch only): 2 Amps

Figure .1

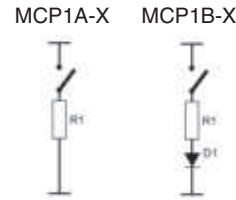

Environmental Specification

Humidity: 93± 3% non-condensing
 Operating Temperature: -10°C to +55°C
 Storage Temperature: -10°C to +55°C
 Ingress Protection (IP) Rating: IP24D
 For RoHS, WEEE & REACH data please see www.kac.co.uk

Mechanical Specification

Material: PC/ABS
 Weight: 130g Flush
 180g Surface
 Colour: Red, Ral 3001

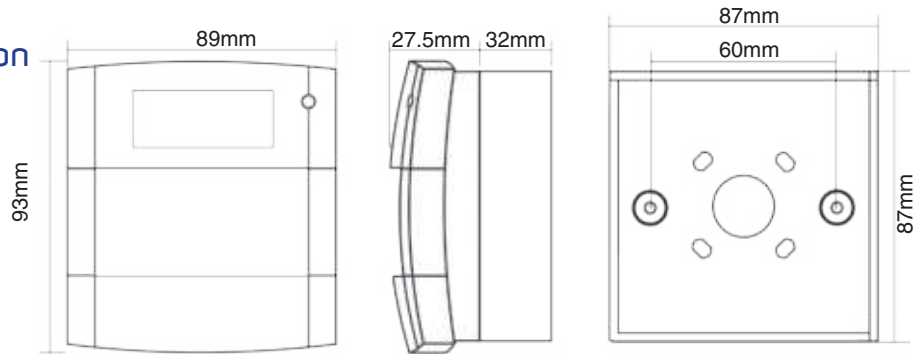

Ordering Information

Model	Electrical Configuration	Mounting	Operating Element	Markings
MCP1A-R470SF-K013-01	470Ω Resistor & N/O 30VDC	Surface	Flexible	EN54-11
MCP1A-R680SF-K013-01	680Ω Resistor & N/O 30VDC	Surface	Flexible	EN54-11
MCP1B-R470FG-K013-01	470Ω Resistor & N/O 30VDC (SAV)	Flush	Glass	EN54-11
MCP1B-R470FF-K013-01	470Ω Resistor & N/O 30VDC (SAV)	Flush	Flexible	EN54-11
MCP1B-R470SG-K013-01	470Ω Resistor & N/O 30VDC (SAV)	Surface	Glass	EN54-11
MCP1B-R470SF-K013-01	470Ω Resistor & N/O 30VDC (SAV)	Surface	Flexible	EN54-11

other variants available on request.

N/O = Normally Open Contact
 SAV = Savwire system

Accessories

Code	Description
SC070	Pack Of Ten Test Keys
KG1 x 5	Pack Of Five Glass Elements (Also available in packs of 10, 25 & 50)
PS210	Flexible Operating Element
PS200	Plain Hinged Cover
SC071	Pack Of Twenty Terminal Blocks

> KAC Alarm Company Ltd

KAC House, Thornhill Road,
 North Moons Moat, Redditch,
 B98 9ND, United Kingdom
 Tel: +44 (0) 1527 406655
 Fax: +44 (0) 1527 406677
 e-mail: marketing@kac.co.uk

